



英格爾科技股份有限公司

ENG ELECTRIC CO., LTD.

Revision: 02

Approval Sheet

CUSTOMER: WW73

CUSTOMER MODEL NO.: _____

ENG MODEL NO.: 3A-10CWX05

ENG PART NO.: 3A-10CWX05-021

DESCRIPTION: Switching Power Supply

DATE: 2012-5-21

| PREPARED | DESIGNED | CHECKED | APPROVED |
|---|---|---|---|
|  |  |  |  |

APPROVAL DATE:

| CUSTOMER APPROVAL | | |
|-------------------|--|--|
| | | |

總部：台灣桃園縣龜山鄉民生北路 1段536號5樓

Head Office: 5F,NO.536, Sec.1, Min Sheng N. Rd.,Kweishan Hsiang,Taoyuan Hsien,Taiwan

TEL: 886-3-2121122 / FAX: 886-3-2121560

工廠：深圳市寶安區福永鎮白石廈中核集團B棟
 Factory: Block B, Nuclear Group industrial District,
 Baishixia, Fuyung Town, Bao'an, Shenzhen, China
 TEL: 86-755-27307512, 27307515
 FAX: 86-755-27308049

工廠：中國廣東省東莞市塘廈鎮林村西湖工業區
 Factory: Lin Village, Xi-Hu Industrial Area,
 Dong-guan City, Guang-Dong, China
 TEL: 86-769-87934928
 FAX: 86-769-87930899

SHENZHEN ENG ELECTRONICS CO., LTD.

FILE NO.: EN-RDS-Y302

FILE: 3A-10CWX05-021

SHEET:01

1 Product Characteristics:

1.1 General Description

Model 3A-10CWX05 is a universal switching-mode power supply, operating at input voltage 90VAC to 264VAC and output voltage of 5VDC with 2A DC load

1.2 Electric Characteristics

1.2.1 Input

| No | ITEM | SPECIFICATION |
|----|-------------------------------|-------------------------------|
| 1. | Rated input Voltage | AC100V-240V |
| | Vibration input Voltage Range | AC90V-264V |
| 2. | Frequency Rated | 50-60Hz |
| | Frequency Vibration | 47-63Hz |
| 3. | Input Rated Current | 300mA RMS Max |
| | Inrush Current | 25A Max .at 115vac cool start |
| | | 50A Max .at 230vac cool start |
| 4. | Leakage current | 0.25mA |
| 5. | Average Efficiency | 73.37% Min CEC Compliant |
| 6. | Standby Power(No Load) | 0.3W Max CEC Compliant |

SHENZHEN ENG ELECTRONICS CO., LTD.

FILE NO.: EN-RDS-Y302

FILE: 3A-10CWX05-021

SHEET: 02

1.2.2 Output:

| No | ITEM | SPECIFICATION |
|----|----------------------------|--|
| 1. | Output Voltage | 5VDC \pm 5% |
| 2. | Output max. Current | 2A |
| 3. | Output min. Current | 0A |
| 4. | Line regulation | \pm 1% |
| 5. | Load regulation | \pm 5% |
| 6. | Short circuit protection | Output shut down and auto restart |
| 7. | Over voltage protection | The output voltage shall be clamped by internal protection zener |
| 8. | Ripple Voltage (Full load) | 240mV (p-p) (100V-240VAC) |

1.2.3 HI-POT SPECIFICATION

Input to output : 3000VAC 10mA 1 minute.

1.2.4 Insulation resistance:

Input to output: 500vdc to test the input to output resistance not be less 100M ohm

1.2.5 Safety approved :

| Type(Marking) | Country/Region | Standard |
|---------------|----------------|---|
| PSE | Japan | Safety : 電気用品の技術上の基準を定める省令第1項別表第八1及び2 (102) |

1.2.6 PB-free standard: RoHS Compliant

SHENZHEN ENG ELECTRONICS CO., LTD.

FILE NO.:EN-RDS-Y302

FILE: 3A-10CWX05-021

SHEET:03

1.3 Mechanical Characteristics

1.3.1 AC plug: Direct plug-In UL Type.

1.3.2 DC cord:

(1)Bending test: Life 1000 times 100% guarantee. Swings 120 from

Left to right loading weight 200g , 40 cycle/minute.

(2)Pull test : DC cord and plug ,weight 6kg for 1 minute.

1.3.3 Cord length and output plug: See Reference Att.4

1.3.4 Weight : 98 g

1.3.5 Case Size: (L)60 X (W) 44 X (H) 25mm

1.3.6 Normal operating temperature and humidity

1.3.7 Temperature

Operating: 0 °C to 40°C

Storage : -10°C to 70°C

1.3.8 Humidity

Operating : 20% to 80%.

Storage: 10% to 90%

SHENZHEN ENG ELECTRONICS CO., LTD.

FILE NO.:EN-RDS-Y302

FILE: 3A-10CWX05-021

SHEET:04

2.Attachment:

- (Att.1) Label
- (Att.2) Outdrawing
- (Att.3) Package
- (Att.3.1) Package flow chart
- (Att.4) DC cord drawing

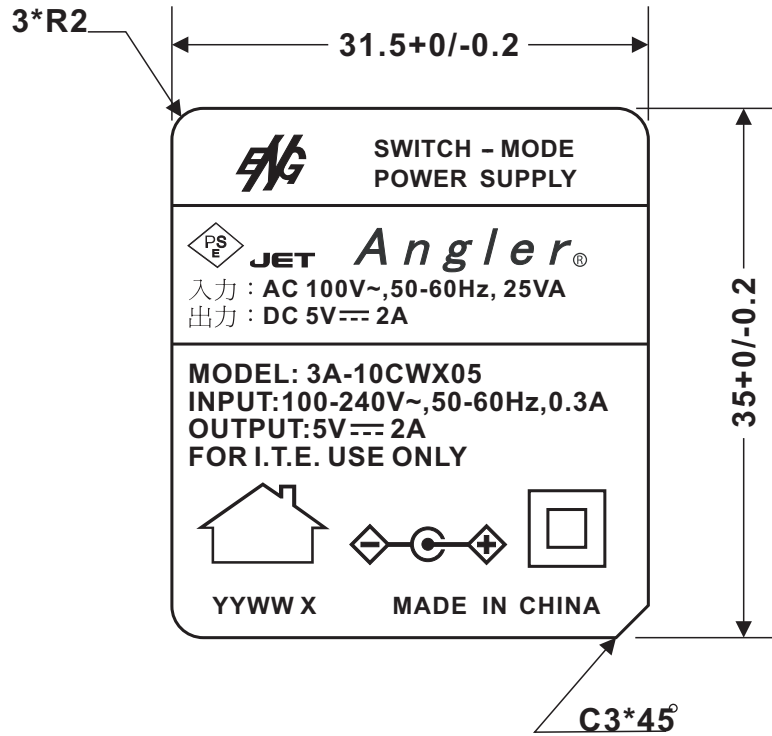

UNIT: mm

YYWW X YY:YEAR WW:WEEK X=S or A(S:FU YONG A:DONG GUAN)

ALUMINUM NAMEPLATE:○ BLACK WORD ON SILVER BASE(銀底黑字)
(鋁板)

○ SILVER WORD ON BLACK BASE(黑底銀字)

METALIZED POLYESTER:○ BLACK WORD ON SILVER BASE(銀底黑字)
(SILVER MATTE)

(消銀龍) ● SILVER WORD ON BLACK BASE(黑底銀字)

3A-10CW05-021

| TOLERANCE | | | | |
|-----------|--|--|--|--|
| | | | | |
| | | | | |

| | | | | | |
|------------------------------------|---------|----------|-------|-----------------|----------|
| DESIGNED | CHECKED | APPROVED | | TITLE | DATE |
| Tanll | Linli | LNB | | UNITS | LABEL |
| | | | mm | DRAWING No. | 12/05/21 |
| | | | SCALE | @N20-WW7300-A28 | |
| SHENZHEN ENG ELECTRONICS CO., LTD. | | | | DRAWING NAME | REVISION |
| | | | | 1002 | 02 |

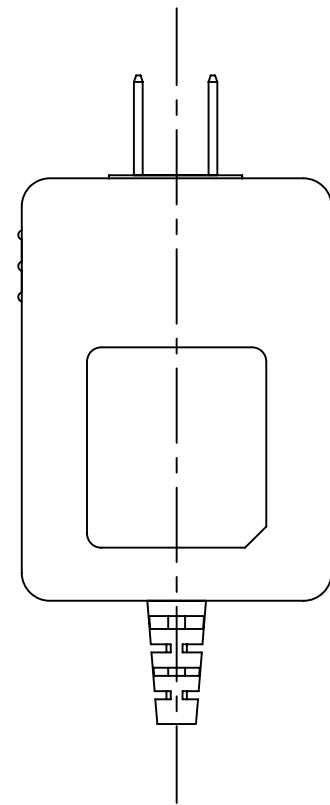
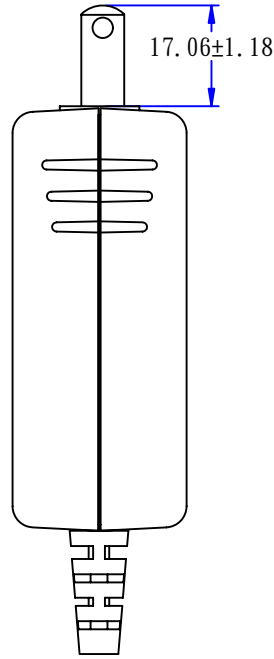
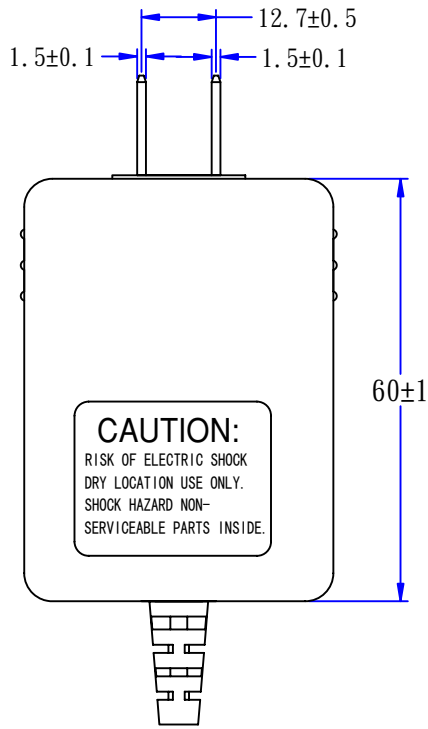
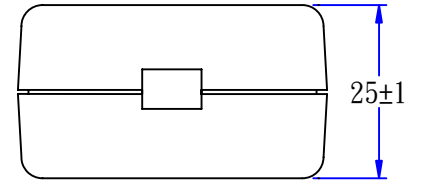
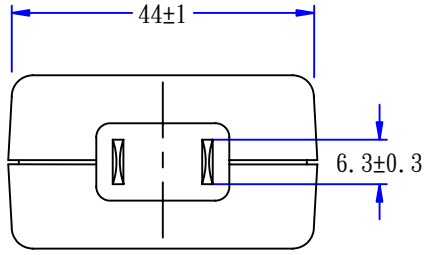

| TOLERANCE | | | | |
|-----------|--|--|--|--|
| | | | | |

| | | | | | |
|------------------------------------|---------------|--------------|-------|--------------|------------|
| DESIGNED | CHECKED | APPROVED | | TITLE | DATE |
| <i>Hump</i> | <i>zhoujg</i> | <i>zhurg</i> | | UNITS | OUTDRAWING |
| | | | mm | DRAWING No. | 07/10/17 |
| | | | SCALE | 100201-001 | |
| SHENZHEN ENG ELECTRONICS CO., LTD. | | | | DRAWING NAME | REVISION |
| | | | | 100201 | 01 |

Att.3

CARTON MATERIAL:A=B(6mm)
 CARTON SIZE:388X380X245mm
 外箱尺寸 388X380X245mm
 Q'TY: 80PCS(20*4)
 數量 80PCS(20*4)

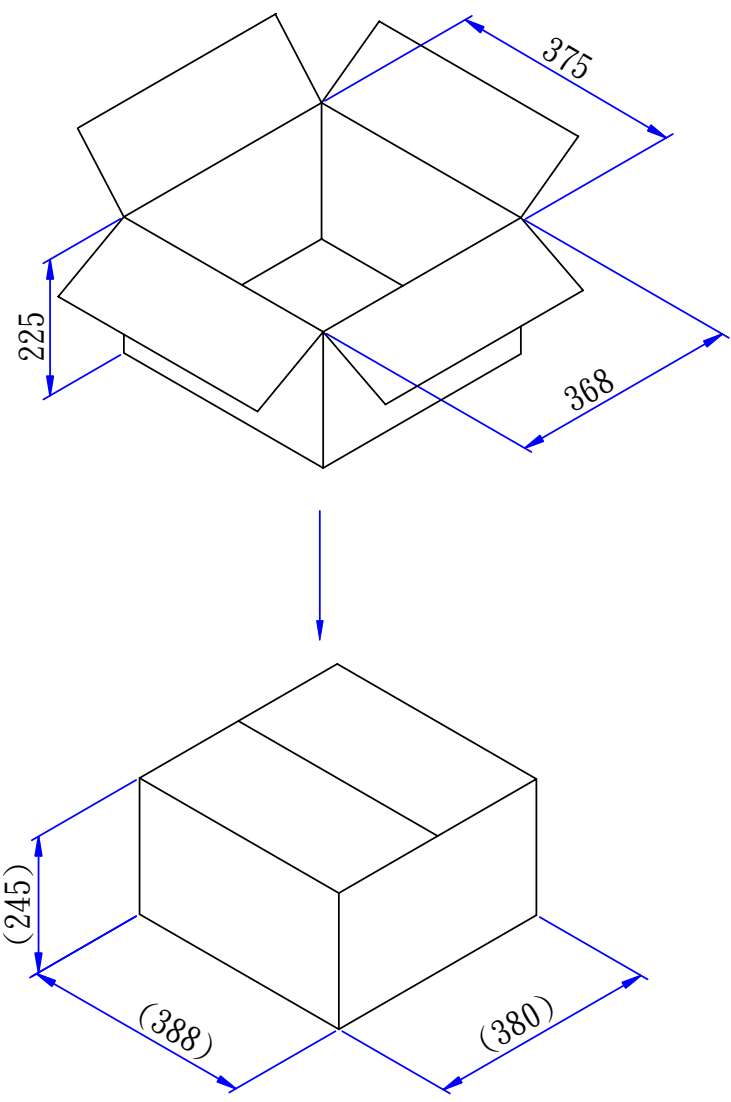

The tolerance of the internal dimensions of the carton is +7/-0
 紙箱內度尺寸公差為+7/-0

| TOLERANCE | | | | |
|-----------|--|--|--|--|
| | | | | |
| | | | | |

| | | | | | | |
|------------------------------------|---------|----------|-------|---------------|----------|-------------|
| DESIGNED | CHECKED | APPROVED | | TITLE | PACKAGE | DATE |
| LQiang | Zhoujg | Zhurg | | UNITS | | DRAWING No. |
| | | | mm | P36-2040-H-50 | | |
| | | | SCALE | DRAWING NAME | REVISION | |
| SHENZHEN ENG ELECTRONICS CO., LTD. | | | | 36-2040-H-50 | 02 | |

Att.3.1

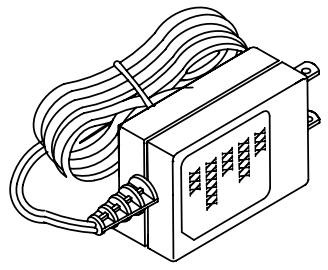

PRODUCT

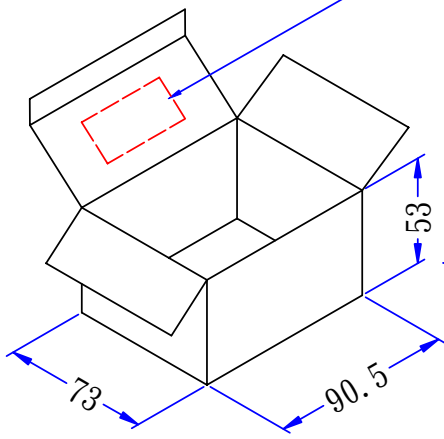

小禮盒上蓋正中間印以下內容:

10CWX05-021

50±1

10±1

WHITE BOX:36#

小禮盒印字面朝上裝入紙箱

The tolerance of the external dimensions of the white box is ±1
 小禮盒外度尺寸公差為±1

| TOLERANCE | | | | |
|-----------|--|--|--|--|
| | | | | |
| | | | | |

| | | | | | |
|------------------------------------|---------|----------|--|--------------------|----------|
| DESIGNED | CHECKED | APPROVED | | TITLE | DATE |
| Dragon | ChenXQ | Bill | | PACKAGE FLOW CHART | 8/3-10 |
| | | | | DRAWING No. | |
| | | | | 3A-10CWX05-021 | |
| | | | | DRAWING NAME | REVISION |
| SHENZHEN ENG ELECTRONICS CO., LTD. | | | | 36# | 01 |

Att.4

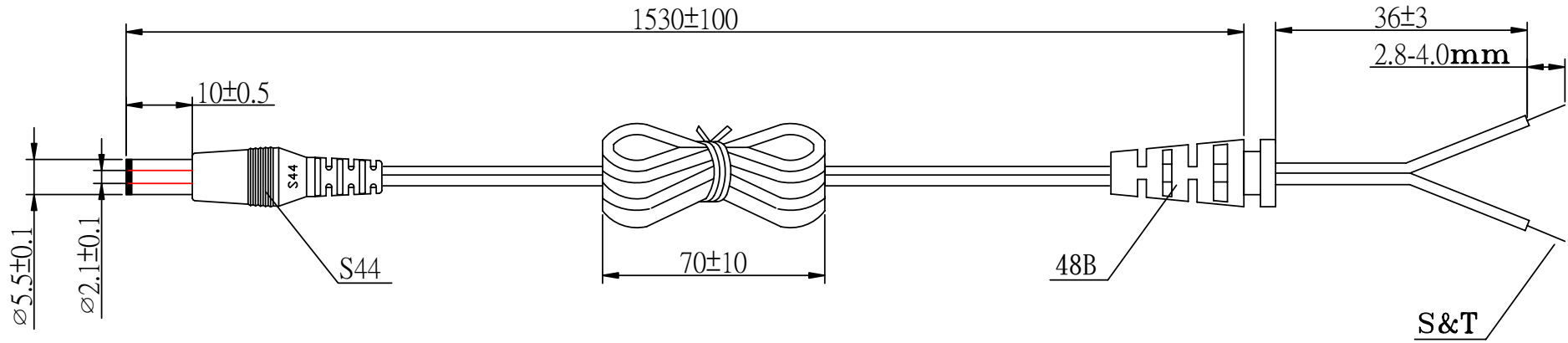

#20AWG X2C UL2468 HAVE ON WORD WIRE IN OUTER, NO WORD WIRE IN INNER(有字接外,無字接內)

OD: $\phi 1.9 \times 3.8$

| TOLERANCE | | | | |
|-----------|--|--|--|--|
| | | | | |

| | |
|---------------------------|------------------------------------|
| 搖擺測試 VIBRATION TEST | a. $\pm 60^\circ$ |
| | b. 吊重200g WEIGHT 200g |
| | c. 40回/分 40 ROUND/MINUTE |
| | d. 1000次/最少 OVER 1000 COUNT MIN |

| DESIGNED | CHECKED | APPROVED | UNITS | | TITLE | DATE |
|-------------------------------|---------|----------|-------|----|----------------------------------|----------------|
| Dragon | ChenXQ | Bill | | mm | DC CORD | 8/3-10 |
| SHENZHEN ENG ELECTRIC CO; LTD | | | | | DRAWING No. 3A-10CWX05-021 | REVISION 01 |
| | | | | | DRAWING NAME 31-48BS44-03B-00 | |