



英格爾科技股份有限公司

ENG ELECTRIC CO., LTD.

Revision: 02

# Approval Sheet

CUSTOMER: WW73

CUSTOMER MODEL NO.:

ENG MODEL NO.: 3A-403DA12

ENG PART NO.: @3A-403DA12-026

DESCRIPTION: Switching Power Supply

DATE: 2009/9/29

PREPARED	DESIGNED	CHECKED	APPROVED

APPROVAL DATE:

CUSTOMER APPROVAL		

總部：台灣桃園縣龜山鄉民生北路1段536號5樓

Head Office: 5F, NO.536, Sec.1, Min Sheng N. Rd., Kweishan Hsiang, Taoyuan Hsien, Taiwan

TEL: 886-3-2121122 / FAX: 886-3-2121560

工廠：深圳市寶安區福永鎮白石廈中核集團B棟

Factory: Block B, Nuclear Group industrial District,  
Baishixia, Fuyung Town, Bao'an, Shenzhen, China

TEL: 86-755-27307512, 27307515

FAX: 86-755-27308049

工廠：中國廣東省東莞市塘廈鎮林村西湖工業區

Factory: Lin Village, Xi-Hu Industrial Area,  
Dong-guan City, Guang-Dong, China

TEL: 86-769-87934928

FAX: 86-769-87930899





# SHENZHEN ENG ELECTRONICS CO., LTD.

FILE NO.: EN-RDS-O402

FILE: @3A-403DA12-025

產品承認書 SHEET: 01

## 1 Product Characteristics:

### 1.1 General Description

Model 3A-403DA12 is a universal switching-mode power supply, operating at input voltage 90VAC to 264VAC and output voltage of 12VDC with 3.3A DC load

### 1.2 Electric Characteristics

#### 1.2.1 Input

No	ITEM	SPECIFICATION
1.	Rated input Voltage	AC100V-240V
	Vibration input Voltage Range	AC90V-264V
2.	Frequency Rated	50-60Hz
	Frequency Vibration	47-63Hz
3.	Input Rated Current	1.0A RMS Max
	Inrush current	NO Damage
4.	Leakage current	0.25mA
5.	Efficiency	85.3% Min (CEC LEVEL V)
6.	Input power(no load)	<0.3W CEC Compliant

# SHENZHEN ENG ELECTRONICS CO., LTD.

FILE NO.:EN-RDS-O424

FILE: @3A-403DA12-026

產品承認書 SHEET:02

## 1.2.2 Output:

No	ITEM	SPECIFICATION
1.	output Voltage	12VDC
2.	output max. current	3.3A
3.	output min. Current	0A
4.	Line regulation	± 1%
5.	Output Voltage tolerance	± 5%
6.	Short circuit protection	Output shut down and auto restart
7.	Ripple Voltage	240mV(p-p) (100V-240VAC at full load)

## 1.2.3 HI-POT SPECIFICATION

Input to output : 3000VAC or 4242VDC 10mA 1 minute

## 1.2.4 Insulation resistance:

Input to output: 500vdc to test the input to output resistance not be less 100M ohm

## 1.2.5 Safety approved:PSE

## 1.2.6 EMI standard : meet FCC class B , CE ,VCCI – II

## 1.2.7 PB-free standard: RoHS Compliant.

# SHENZHEN ENG ELECTRONICS CO., LTD.

FILE NO.: EN-RDS-O424

FILE: @3A-403DA12-026

產品承認書 SHEET: 03

---

## 1.3 Mechanical Characteristics

1.3.1 AC Plug : INLET IEC320/C8-2 Type

1.3.2 DC cord:

(1) Bending test: Life 1000 times 100% guarantee. Swings 120 from

Left to right loading weight 200g , 40 cycle/minute.

(2) Pull test : DC cord and plug , weight 6kg for 1 minute.

1.3.3 Cord length and output plug: See Reference Att.4

1.3.4 Weight : 160 g

1.3.5 Case Size: (L)75 X (W) 47.5X (H) 27.3mm

1.3.6 Normal operating temperature and humidity

1.3.7 Temperature

Operating: 0°C to 40°C

Storage : -10°C to 70°C

1.3.8 Humidity

Operating : 20% to 80%.

Storage: 10% to 90%

# SHENZHEN ENG ELECTRONICS CO., LTD.

FILE NO.: EN-RDS-O424

FILE: @3A-403DA12-026

產品承認書 SHEET: 04

---

## 2.Attachment:

- (Att.1) Label
- (Att.2) Outdrawing
- (Att.3) Package
- (Att.3.1) Package flow chart
- (Att.4) Dc cord drawing
- (Att.5) Electrical test report

Att.1

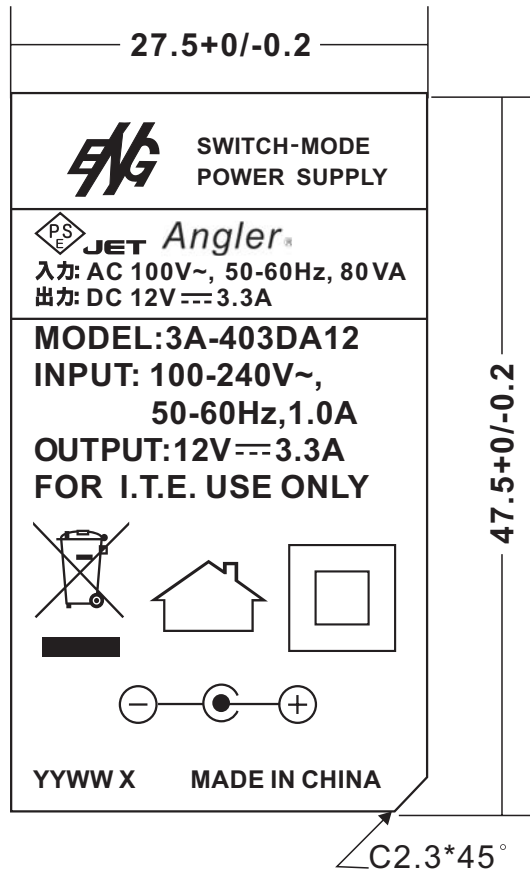

UNIT: mm

YYWW X YY:YEAR WW:WEEK X=S or A(S:FU YONG A:DONG GUAN)

ALUMINUM NAMEPLATE: ○ BLACK WORD ON SILVER BASE  
鋁板 銀底黑字

○ SILVER WORD ON BLACK BASE  
黑底銀字

METALIZED POLYESTER: ○ BLACK WORD ON SILVER BASE  
消銀龍 銀底黑字  
(SILVER MATTE) ● SILVER WORD ON BLACK BASE  
黑底銀字

TOLERANCE

\*@3A-403DA12-026

DESIGNED	CHECKED	APPROVED		TITLE	DATE
Wsong	Gujj	Zhurg		UNITS	<b>LABEL</b> DRAWING NO. @N20-WW7300-A08
			mm	SCALE	
			2:1	DRAWING NAME	02
SHENZHEN ENG ELECTRONICS CO., LTD.				1209	



Att.2

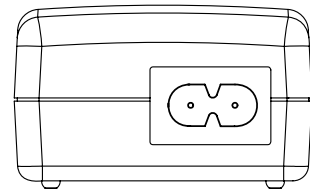
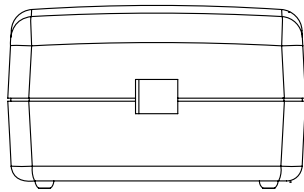
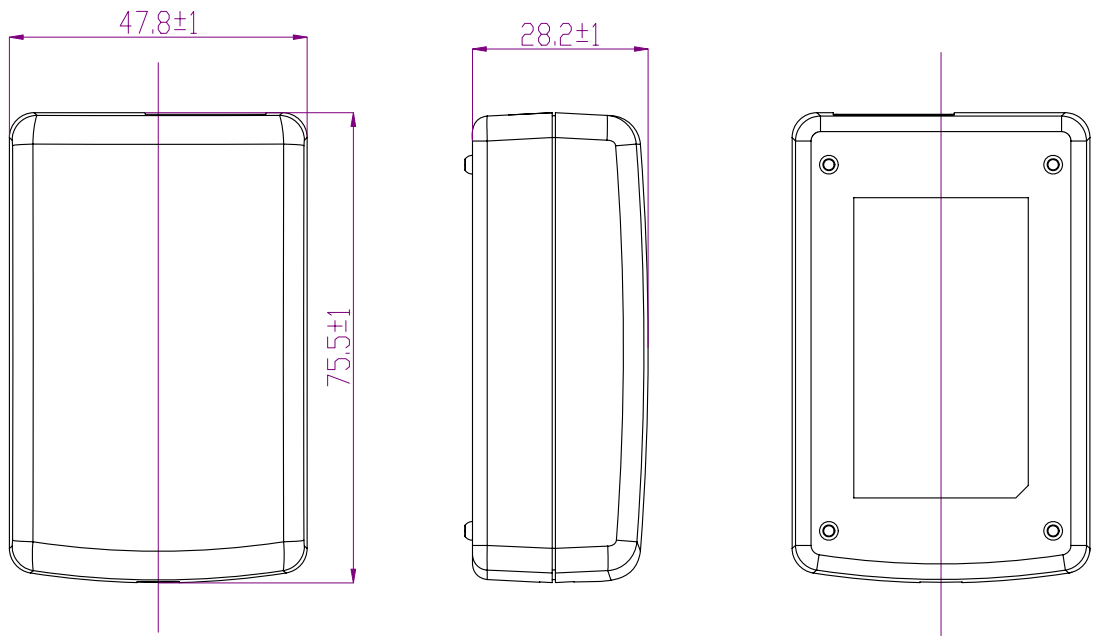

TOLERANCE				

DESIGNED	CHECKED	APPROVED		TITLE	DATE
<i>Tanll</i>	<i>LiuC</i>	<i>Zhurg</i>		UNITS	OUTDRAWING
SHENZHEN ENG ELECTRONICS CO., LTD.			mm	DRAWING No.	REVISION
			SCALE	121611-001	
				DRAWING NAME	
				121611	

Att.3

箱内度尺寸 375\*368\*225mm

Q'TY: 80PCS(20\*4)

數量 80PCS(20\*4)

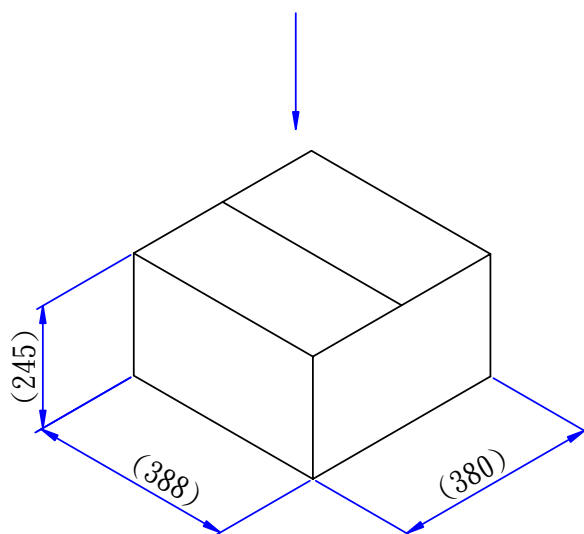
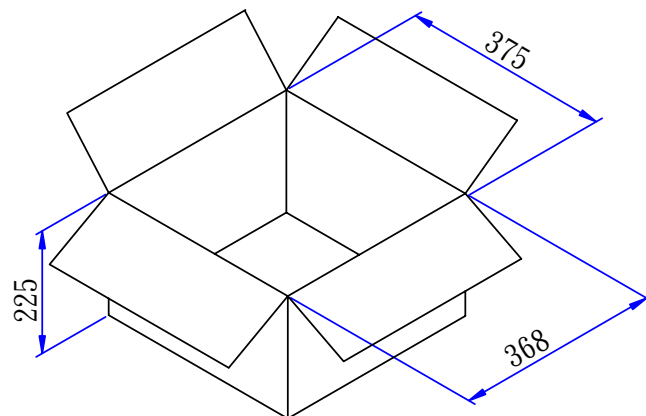

The tolerance of the internal dimensions of the carton is +7/-0

纸箱内度尺寸公差为+7/-0

TOLERANCE				

DESIGNED	CHECKED	APPROVED		TITLE	PACKAGE	DATE
Tanll	LiuC	Zhurg		UNITS	mm	DRAWING No.
SHENZHEN ENG ELECTRONICS CO., LTD.				SCALE	P36-2040-H-50	REVISION
					36-2040-H-50	01

Att.3.1

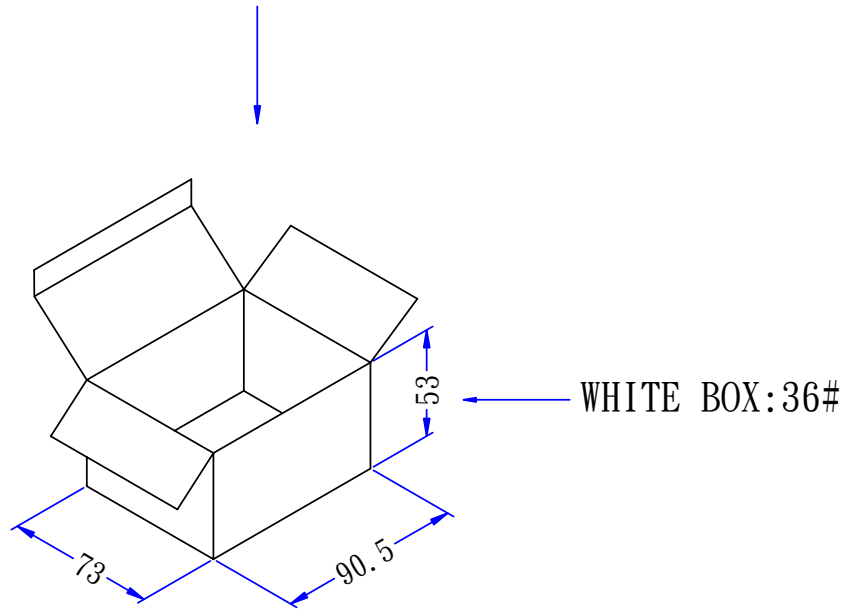
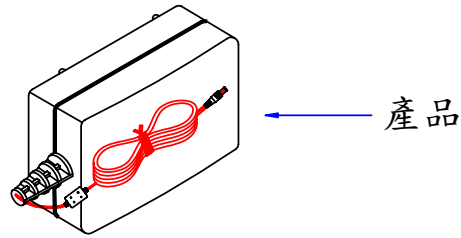

The tolerance of the external dimensions of the white box is  $\pm 1$   
 小禮盒外度尺寸公差为 $\pm 1$

TOLERANCE				

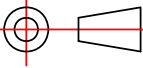
DESIGNED	CHECKED	APPROVED		TITLE	DATE
Tanll	LiuC	Zhurg		UNITS	PACKAGE FLOW CHART
SHENZHEN ENG ELECTRONICS CO., LTD.			mm	DRAWING No.	REVISION
			SCALE	@3A-403DA12-026	
				DRAWING NAME	
				36#	

Att.4

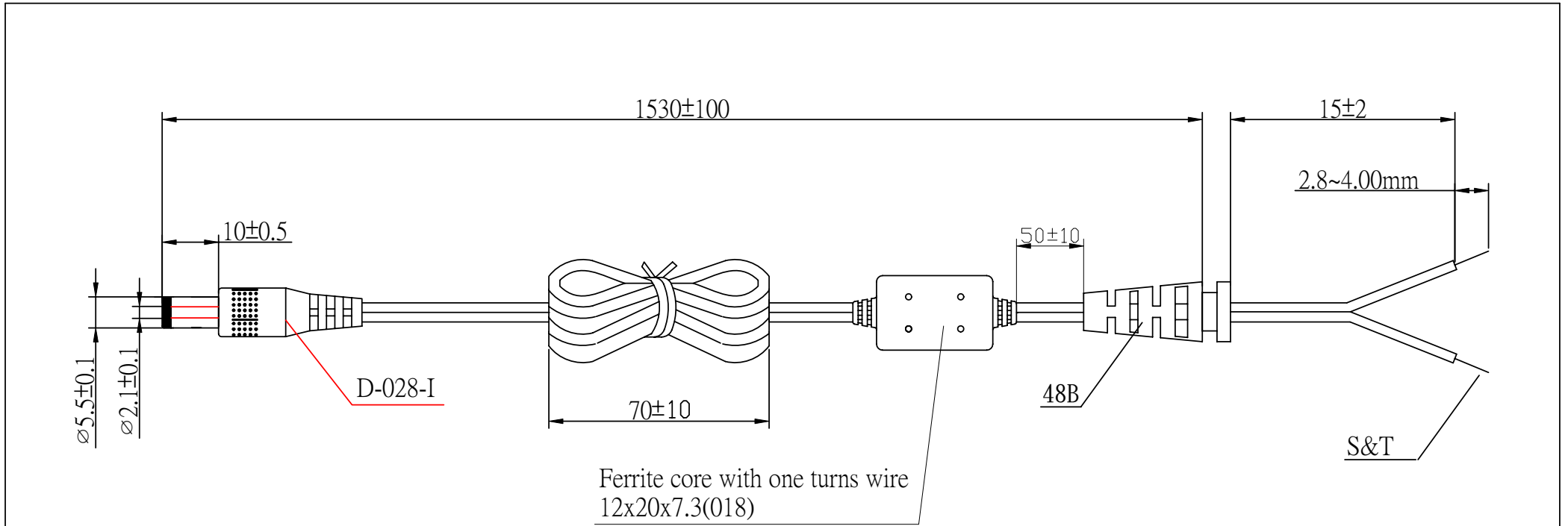

#18AWGX2C UL2468 HAVE ON WORD WIRE IN OUTER, NO WORD WIRE IN INNER(有字接外，無字接內)  
 OD:  $\varnothing 2.2 * 4.4$

TOLERANCE				

Parameter request	
搖擺測試 VIBRATION TEST	a. $\pm 60^\circ$ b. 吊重200g WEIGHT 200g c. 40回/分 40 ROUND/MINUTE d. 1000次/最少 OVER 1000 COUNT MIN

DESIGNED	CHECKED	APPROVED	TITLE		DATE
LQiang	GuJJ	ZhuRG	UNITS	DC CORD	09/09/29
SHENZHEN ENG ELECTRONICS CO., LTD.			mm	DRAWING No.	REVISION
			SCALE	@3A-403DA12-026	
			DRAWING NAME		
			41-48BXXX-03B-00		

平成21年 8月 3日

August 3, 2009

SHENZHEN ENG ELECTRONICS CO., LTD.  
GENERAL MANAGER SCOTT.HSIAO

東京都渋谷区代々木5-14-12  
財団法人 電気安全環境研究所  
製品認証部

5-14-12, Yoyogi, Shibuya-Ku, Tokyo  
Japan Electrical Safety & Environment technology Laboratories (JET)  
Product Certification Division

平成21年 7月 8日 付けでお申込みいただきました下記の特定電気用品につきましては、同封の適合性同等検査合格書のとおり平成21年 8月 3日付にて発行され、平成26年 8月 2日まで有効であることをお知らせします。

I hereby inform you that with respect to the application of Jul 8, 2009, for conformity assessment for the specified product hereunder, the certificate, as enclosed herewith, was issued on Aug 3, 2009 and the term of validity of this certificate is from the date of its issue to Aug 2, 2014.

### 記

1. 受付番号 : A09K0240A

Project No.

2. 特定電気用品名 : 直流電源装置

Name of Product DC power supply units

3. 製品の型 : 3A-484DA12

Model

4. 合格書番号 : JET1691-61010-1017

Statement Number

5. 製造工場名 (Manufacturer)

住所 : NUCLEAR GROUP INDUSTRIAL DISTRICT, BAISHIXIA, FUYUN  
TOWN, BAO'AN, SHENZHEN, CHINA

氏名又は名称 : SHENZHEN ENG ELECTRONICS CO., LTD.

Name

NO. 5, XI-FA ROAD, XI-HU INDUSTRIAL DISTRICT, LIN  
VILLAGE, TANG XIA, TOWN, DONG-GUAN CITY, GUANG-DONG  
PROVINCE, CHINA

DONGGUAN ENG ELECTRONICS CO., LTD.

6. 型式 : (Type)

100~240V, 80~101VA, 50-60Hz, 交流用端子なし, 直流12V,  
変圧器E種絶縁, 直流電圧調整装置なし, 回路保護あり, 器体スイッチなし, 合成樹脂外郭, 一般機器用, 接続器接続, 二重絶縁なし

# 適合性同等検査合格書

Statement of Conformity Assessment

電気用品安全法第8条第1項に規定する技術基準及び同法第9条第2項の経済産業省令で定める基準（法第9条第1項第2号に係る検査に係るものに限る）に適合していることを証明します

I hereby certify that the product mentioned below complies with the technical requirements stipulated in Paragraph 1 of Article 8 of Electrical Appliance and Material Safety Law (hereunder referred to as the Law) and the requirements defined by the ordinance of the Ministry of Economy, Trade and Industry based on Paragraph 2 of Article 9 of the Law (limited to Item 2 of Paragraph 1 of Article 9 for Inspection of the Law).

1. 合格書番号: JET1691-61010-1017  
Statement Number
2. 発行年月日: 平成21年 8月 3日  
Date of Issue August 3, 2009
3. 有効年月日: 平成26年 8月 2日  
Date of Validity August 2, 2014
4. 申込者名 (Applicant)  
住所: NUCLEAR GROUP INDUSTRIAL DISTRICT, BAISHIXIA,  
Address FUYUN TOWN, BAO'AN, SHENZHEN, CHINA

氏名又は名称: SHENZHEN ENG ELECTRONICS CO., LTD.  
Name

5. 特定電気用品名: 直流電源装置  
Name of Product DC power supply units
6. 型式の区分: 別紙のとおり  
Type Classification See attached "Type Classification"
7. 製造工場名 (Manufacturer)  
住所: 別紙のとおり  
Address See attached "Manufacturer Address"

氏名又は名称: 別紙のとおり  
Name See attached "Manufacturer Name"

8. 適用試験規格: 電気用品の技術上の基準を定める省令第1項  
Applied Standard for Testing Article 1 of The Technical Requirements of the METI Ordinance  
別表第八1及び2 (102)

Appendix 8 Section 1 and Section 2 Chapter 102

9. 適合性検査の方法: (Testing Method for Conformity Assessment)

- 1) 試験用の特定電気用品については、電気用品の技術上の基準を定める省令に定める方法

With respect to testing for Category A products, the testing method is based on the technical requirements of the Electrical Appliance and Material stipulated in the METI Ordinance.

- 2) 当該特定電気用品に係る届出事業者又は事業場における検査設備については、電気用品安全法施行規則別表第四の検査設備の欄に掲げる検査設備ごとにそれぞれ同表の技術上の基準の欄に掲げる方法

With respect to inspection facilities required for Category A products at the factory, Testing Method described in the column of the technical requirements for each inspection facilities in the column of inspection facilities is shown in the Appendix 4 of Enforcement Regulations of the Law.

財団法人 電気安全環境研究所  
Japan Electrical Safety & Environment technology Laboratories (JET)

理事長 末廣 恵雄  
President Shigeo Suehiro

東京都渋谷区代々木5-14-12 (5-14-12, Yoyogi, Shibuya-ku, Tokyo)

# 適合性同等検査合格書別紙

Statement of Conformity Assessment

製 造 工 場 名

Manufacturer

(1) 住 所 : NUCLEAR GROUP INDUSTRIAL DISTRICT, BAISHIXIA,  
Address FUYUN TOWN, BAO'AN, SHENZHEN, CHINA  
氏名又は名称 : SHENZHEN ENG ELECTRONICS CO., LTD.  
Name

(2) 住 所 : NO.5, XI-FA ROAD, XI-HU INDUSTRIAL DISTRICT,  
Address LIN VILLAGE, TANG XIA, TOWN, DONG-GUAN CITY,  
GUANG-DONG PROVINCE, CHINA  
氏名又は名称 : DONGGUAN ENG ELECTRONICS CO., LTD.  
Name

合格書番号 : J E T 1 6 9 1 - 6 1 0 1 0 - 1 0 1 7

# 適合性同等検査合格書別紙

Statement of Conformity Assessment

## 型式の区分

Type Classification

要素 Factor	区分 Classification
定格入力電圧 Rated input voltage	(1) 125V以下のもの 125V or less
	(2) 125Vを超えるもの Exceeding 125V
入力側の定格容量 Rated capacity on input side	(8) 70VAを超え80VA以下のもの Exceeding 70VA, and less than or equal to 80VA
	(11) 100VAを超え200VA以下のもの Exceeding 100VA, and less than or equal to 200VA
定格周波数（変圧器を有するものの場合に限る。） Rated frequency (limited to those with transformers)	(1) 50Hzのもの 50Hz
	(2) 60Hzのもの 60Hz
交流用端子 Alternating current terminal	(2) ないもの Without A.C. terminal
直流定格電圧 Rated direct current voltage	(1) 15V以下のもの 15V or less
変圧器 Transformer	(1) あるもの With transformer
変圧器の巻線の絶縁の種類 Transformer winding insulation class	(2) E種のもの Class E
直流電圧の調整装置 D.C. voltage adjusting mechanism	(2) ないもの Without adjusting mechanism
回路の保護機構 Circuit protection device	(1) あるもの With circuit protection device
器体スイッチ（主回路を開閉するものの場合に限り、自動スイッチ及び自動温度調節器を除く。） Body switch (limited to those used for turning the main circuit on and off, and excluding temperature limiters and thermostats.)	(2) ないもの Without body switch
外郭の材料 Outer case materials	(2) 合成樹脂のもの Plastic
用途 Application	(4) その他のもの Others
電源電線と器体との接続の方式 Power supply connections	(2) 接続器利用のもの Coupling device
二重絶縁 Double insulation	(2) 施していないもの Without double insulation

合格書番号：JET1691-61010-1017



# 適合性同等検査合格書別紙

Statement of Conformity Assessment

## 型式の区分

Type Classification

要素 Factor	区分 Classification
これ以下、組み合わせ The combinations of the above classifications are as follows.	
定格入力電圧 Rated input voltage	(1) 125V以下のもの 125V or less
入力側の定格容量 Rated capacity on input side	(8) 70VAを超え80VA以下のもの Exceeding 70VA, and less than or equal to 80VA
組み合わせ The combinations	
定格入力電圧 Rated input voltage	(2) 125Vを超えるもの Exceeding 125V
入力側の定格容量 Rated capacity on input side	(11) 100VAを超え200VA以下のもの Exceeding 100VA, and less than or equal to 200VA

合格書番号 : J E T 1 6 9 1 - 6 1 0 1 0 - 1 0 1 7