



英格爾科技股份有限公司

ENG ELECTRIC CO., LTD.

Revision: 01

Approval Sheet

CUSTOMER: _____

CUSTOMER MODEL NO.: _____

ENG MODEL NO.: 3A-602DA12

ENG PART NO.: _____

DESCRIPTION: SWITCHING POWER SUPPLY

DATE: 2009/4/15

PREPARED	DESIGNED	CHECKED	APPROVED

APPROVAL DATE:

CUSTOMER APPROVAL		

總部：台灣桃園縣龜山鄉民生北路 1段536號5樓

Head Office: 5F,NO.536, Sec.1, Min Sheng N. Rd.,Kweishan Hsiang,Taoyuan Hsien,Taiwan

TEL: 886-3-2121122 / FAX: 886-3-2121560

工廠：深圳市寶安區福永鎮白石廈中核集團B棟
Factory: Block B, Nuclear Group industrial District
Baishixia, Fuyong Town, Bao'an, Shenzhen, China
TEL: 86-755-27307512, 27307515
FAX: 86-755-27308049

工廠：中國廣東省東莞市塘廈鎮林村西湖工業區
Factory: Lin Village, Xi-Hu Industrial Area,
Dong-guan City, Guang-Dong, China
TEL: 86-769-87934928
FAX: 86-769-87930899

SHENZHEN ENG ELECTRONICS CO., LTD.

FILE NO.: EN-RDS-O125

FILE: @3A-602DA12-021

SHEET:01

1 Product Characteristics:

1.1 General Description

Model 3A-602DA12 is a universal switching-mode power supply, operating at input voltage 90VAC to 264VAC and output voltage of +12V with 5A DC load

1.2 Electric Characteristics

(Att. 1.2.1 Input

No	ITEM	SPECIFICATION
1.	Rated input Voltage	AC100-240V
	Vibration input Voltage Range	AC90-264V
2.	Frequency Rated	50 / 60Hz
	Frequency Vibration	47-63Hz
3.	Input Rated Current	1.4A RMS MAX
	Inrush Current	No damage at 240V AC Cold Start
4.	Leakage current	<0.25mA
5.	Efficiency	87% Min (CEC Level IV Compliant)
6.	No Load Consumption	<0.3W Max(CEC Level IV Compliant)
7.	power factor	N/A

SHENZHEN ENG ELECTRONICS CO., LTD.

FILE NO.:EN-RDS-O125

FILE : @3A-602DA12-021

SHEET:02

1.2.2 Output:

No	ITEM	SPECIFICATION
1.	Output Voltage	12VDC±5%
2.	Output max. Current	5A
3.	Output min. Current	0
4.	Line regulation	± 1%
5.	Output voltage protection	N/A
6.	Short circuit protection	Output shut down and auto restart
7.	Over temperature protection	There shall be no ignition or smoke and deformation of case
8.	Ripple Voltage	150mV (p-p) (100-240V AC Input) (1)

(1).Measuring is done by 20MHz bandwidth oscilloscope and terminated each output with a 10uf aluminum electrolytic and 0.1uf ceramic capacitor.

1.2.3 HI-POT SPECIFICATION

Input to output 3000VAC or 4242VDC 10mA 1 minute.

1.2.4 Insulation resistance:

Input to output: 500VDC to test the input to output resistance not be less 100M ohm

1.2.5 Safety approved: UL/CUL CE PSE

1.2.6 EMI standard : FCC class B,CE,VCCI

1.2.7 PB-free standard: RoHS Compliant

SHENZHEN ENG ELECTRONICS CO., LTD.

FILE NO.: EN-RDS-O125

FILE: @3A-602DA12-021

SHEET: 03

1.3 Mechanical Characteristics

1.3.1 AC Plug :INLET IEC320 /C8Type.

1.3.2 DC cord:

(1) Bending test: Life 1000 times 100% guarantee. Swings 120 from

Left to right loading weight 200g , 40 cycle/minute.

(2) Pull test : DC cord and plug ,weight 6kg for 1 minute.

1.3.3 Cord length and output plug: See Reference Att.4

1.3.4 Weight : 278 g

1.3.5 Case Size: (L)116 X (W)50X (H)31mm

1.3.6 Normal operating temperature and humidity

1.3.7 Temperature

Operating: 0 °C to 40°C

Storage : -10°C to 70°C

1.3.8 Humidity

Operating : 20% to 80%.

Storage: 10% to 90%

SHENZHEN ENG ELECTRONICS CO., LTD.

FILE NO.: EN-RDS-O125

FILE: @3A-602DA12-021

SHEET: 04

2.Attachment:

- (Att.1) Label
- (Att.2) Outdrawing
- (Att.3) Package
- (Att.3.1) Package flow chart
- (Att.4) Dc cord drawing
- (Att.5) Dc cord drawing

Att.1

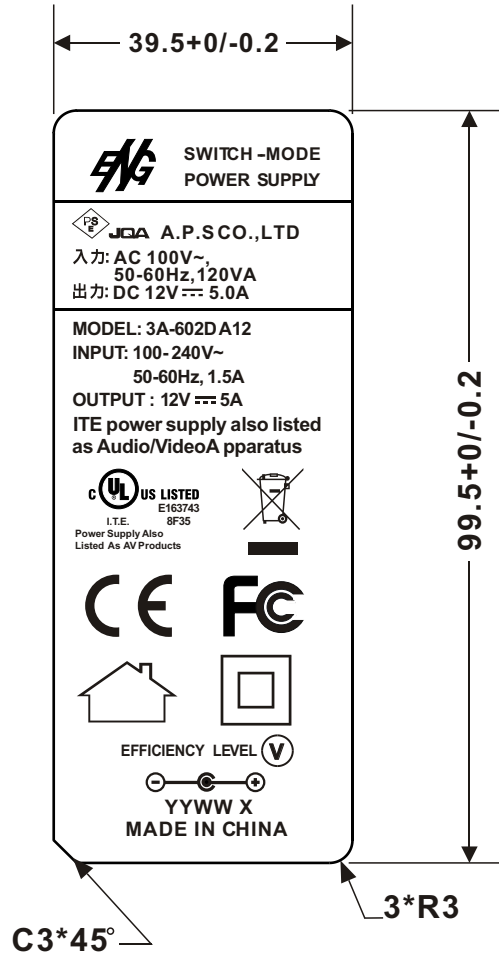

UNIT: mm

YYWW X YY:YEAR WW:WEEK X=S or A(S:FU YONG A:DONG GUAN)

ALUMINUM NAMEPLATE: ○ BLACK WORD ON SILVER BASE

○ SILVER WORD ON BLACK BASE

METALIZED POLYESTER: ○ BLACK WORD ON SILVER BASE

(SILVER MATTE): ● SILVER WORD ON BLACK BASE

	UL/CUL	GS	FCC	CE	RCM	PSE	CCC	EK	CB
FU YONG(S)	●	○	●	●	○	●	○	○	○
DONG GUAN(A)	●	○	●	●	○	○	○	○	○

TOLERANCE				

DESIGNED	CHECKED	APPROVED	TITLE		DATE
<i>Gjing</i>	<i>LinLi</i>	<i>Zhung</i>	LABEL		
			UNITS	mm	DRAWING No.
			SCALE	1:1	09/05/06
SHENZHEN ENG ELECTRONICS CO., LTD.			DRAWING NAME		REVISION
			6005		01

Att.2

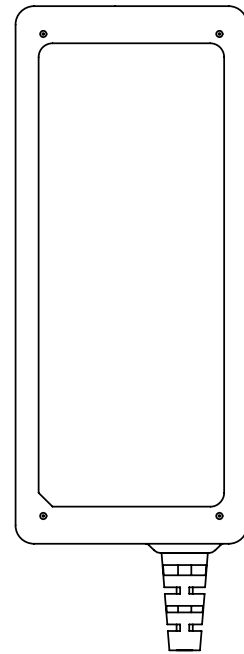
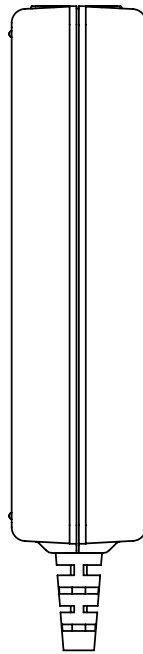
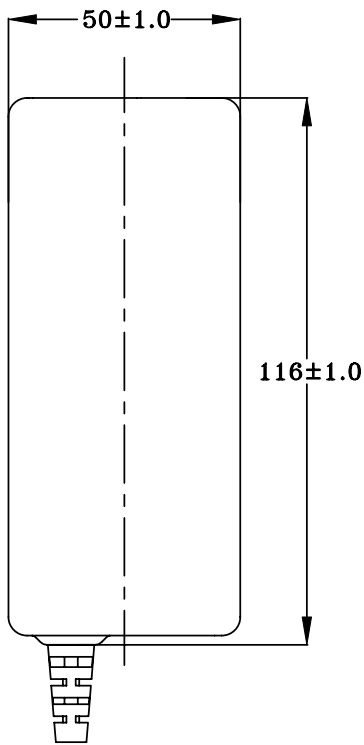
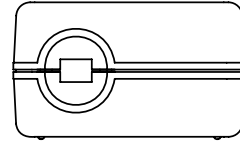
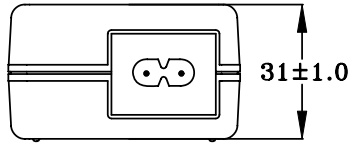

TOLERANCE				

DESIGNED	CHECKED	APPROVED		TITLE	DATE
<i>Hump</i>	<i>Zhoujg</i>	<i>Zhurq</i>		UNITS	OUTDRAWING
			SCALE	DRAWING No.	07/10/15
SHENZHEN ENG ELECTRONICS CO., LTD.				DRAWING NAME	REVISION
				600511	01

Att.3

CARTON SIZE: 483*375*212mm
 外箱尺寸: 483*375*212mm
 PARTITION BOARD: 470X362X3mm(4pcs)
 CROSS-CONNECTING BOARD: 470X60X6mm(18pcs)
 CROSS-CONNECTING BOARD: 362X60X6mm(12pcs)
 Q' TY: 45PCS(15PCS*3)
 數量: 45PCS(15PCS*3)

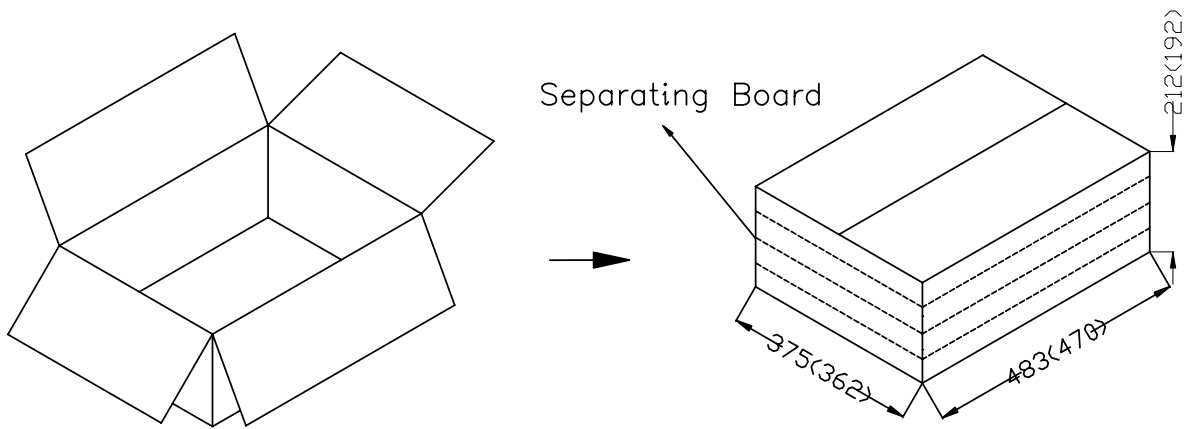
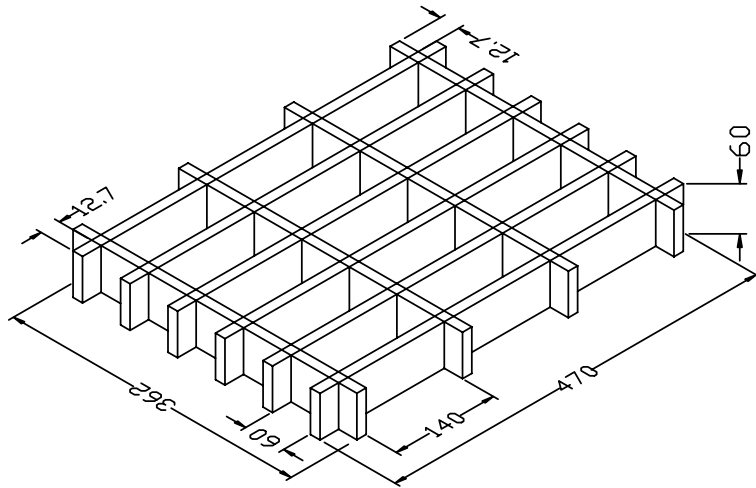

The tolerance of the internal dimensions of the carton is +7/-0

TOLERANCE				

DESIGNED	CHECKED	APPROVED		TITLE	DATE
<i>Hump</i>	<i>Zhoujg</i>	<i>Zhurg</i>		PACKAGE	
			UNITS	mm	DRAWING No.
			SCALE		PBG-1530-H-50
SHENZHEN ENG ELECTRONICS CO., LTD.				DRAWING NAME	REVISION
				BG-1530-H-50	01

Att.3.1

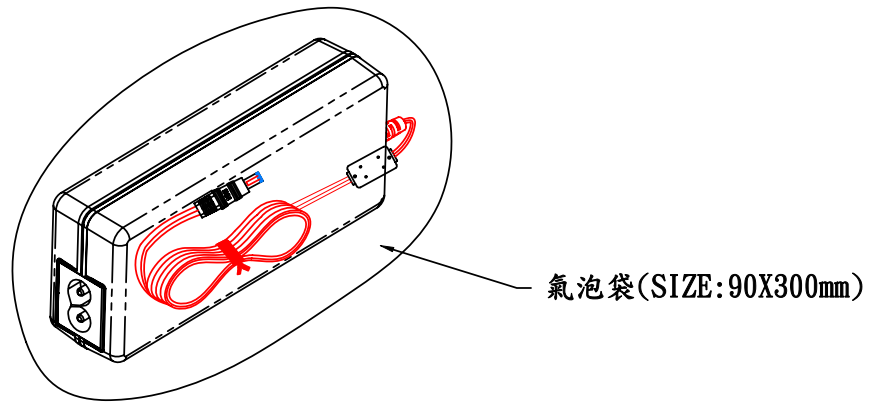

TOLERANCE				

DESIGNED	CHECKED	APPROVED	UNITS		TITLE	DATE
<i>Gjing</i>	<i>LinLi</i>	<i>Zhung</i>		mm		
SCALE					DRAWING No.	REVISION
SHENZHEN ENG ELECTRONICS CO., LTD.					@3A-602DA12-021	
					DRAWING NAME	
					90*300	

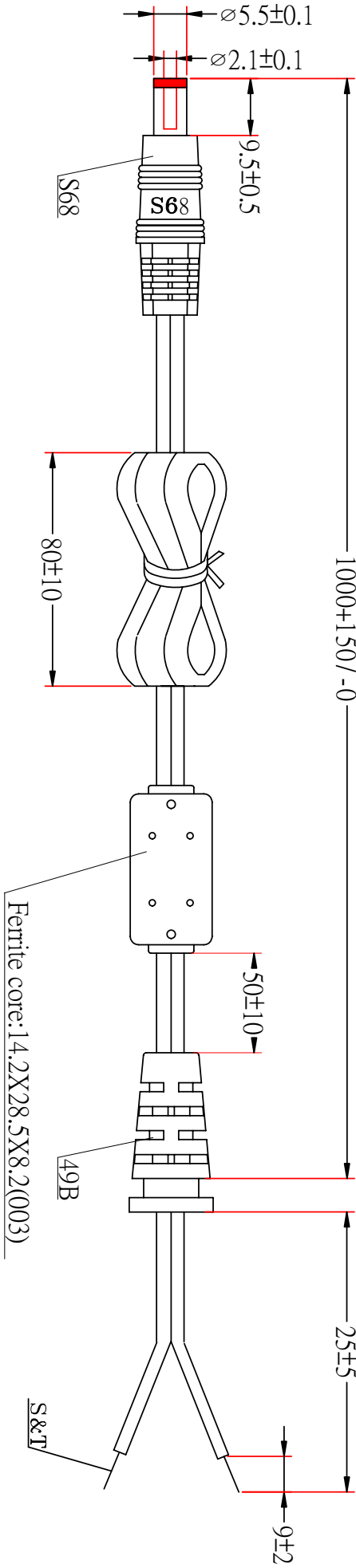

16AWGX2C SPT-2 105°C HAVE ON WORD WIRE IN OUTER, NO WORD WIRE IN INNER(有字接外,無字接內)
 OD:∅3.7*7.4

TOLERANCE

Parameter request	
VIBRATION TEST	a. ±60° b. WEIGHT 200g c. 40 ROUND/MINUTE d. OVER 1000 COUNT MIN

DESIGNED	CHECKED	APPROVED			
LQiang	Li nLi	Zhu RG	UNITS	mm	SCALE

TITTLE	DC CORD	DATE
DRAWING No. @3A-602DA12-021	DRAWING NAME 63-49BS68-03B-00	REVISION 01