

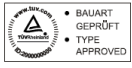

CFM21 SERIES

20 WATT SINGLE OUTPUT AC-DC MODULES



UL 60950-1
And CSA C22
NO.60950-1-07
APPROVED



IEC
60601-1
EN
60601-1



Features

- * Universal Input Range 90-264VAC
- * Miniature Size, Low Profile 0.8"
- * Industry-Standard Pin Out
- * Efficiency to 85%
- * Option for On-board, Connector, Screw Terminal Or Encapsulated type
- * Continuous Short Circuit Protection
- * Over Voltage Protection
- * No load input power < 0.3W
- * Leakage Current < 0.1mA
- * UL60601-1/IEC60601-1/EN60601-1 Medical safety approved
- * UL60950-1/IEC60950-1/EN60950-1 ITE safety approved



MODEL	INPUT VOLTAGE	OUTPUT VOLTAGE	MIN. LOAD	MAX. LOAD	Output Rated Power	RIPPLE & NOISE	VOLTAGE ACCURACY	% EFF.
CFM21S033	90-264VAC	3.3V	0	4.0A	13.2W	50mV	±1%	75 %
CFM21S050	90-264VAC	5.0V	0	4.0A	20.0W	50mV	±1%	80 %
CFM21S090	90-264VAC	9.0V	0	2.3A	20.7W	90mV	±1%	81 %
CFM21S120	90-264VAC	12V	0	1.7A	20.4W	100mV	±1%	83 %
CFM21S150	90-264VAC	15V	0	1.4A	21.0W	100mV	±1%	84 %
CFM21S240	90-264VAC	24V	0	0.9A	21.6W	100mV	±1%	85 %

Specifications

INPUT SPECIFICATIONS:

Voltage 90~264Vac
 Frequency 47 to 63Hz
 Input Current 0.3 to 0.5A
 Inrush Current Cold Start@25°C 40A max. @230Vac
 Leakage Current 0.1mA max.

OUTPUT SPECIFICATIONS:

Voltage Accuracy: ±1.0% max.
 Line Regulation (note 3) ±0.5% max.
 Load Regulation (note 4) ±1.0% max.
 Holdup Time 10ms typ. @115Vac
 Short Circuit Protection Continuous
 Over Voltage Protection(TVS) 115%-140% of nominal output voltage

GENERAL SPECIFICATIONS:

Efficiency see Table
 Switching Frequency 100KHz typ.
 Isolation Input to output = 5656VDC
 Operating Temperature -25 ~ 70°C (with de-rating)
 Storage Temperature -40~85°C
 Cooling Natural Convection
 Humidity 93% RH max. Non condensing
 MTBF MIL-STD-217F, GB 650K hrs min.
 Dimensions 2.38x1.60x0.80Inches (60.5x40.6x20.4mm)
 -T: 3.00x1.60x0.77Inches (76.2x40.6x19.5mm)
 Weight 50g, 55g(-T)

Mechanical Specification

CFM21SXXX

All Dimensions In Inches[mm]
 Tolerance: Inches:x.xx= ±0.02,x.xxx= ±0.01
 Millimeters:x.x= ±0.5,x.xx= ±0.25

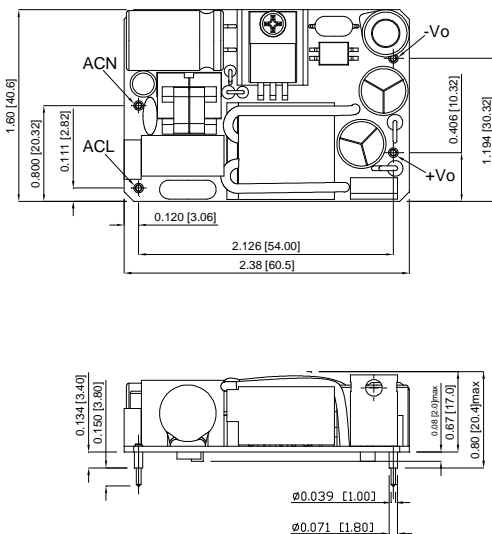

CFM21 Series De-rating Curve

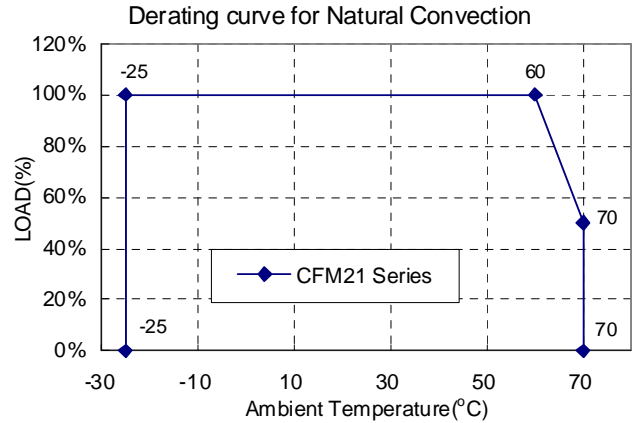

SAFETY AND EMISSION:

CE Directive 2004/108/EC, 93/42/EEC
 Emissions ... EN60601-1/EN61204-3/EN55022/CISPR Class B, EN55024
 Safety Approvals UL60601-1, IEC60601-1, EN60601-1
 UL60950-1, IEC60950-1, EN60950-1

NOTE:

1. Voltage accuracy is set of 100% rated load.
2. Add a 0.1uF ceramic capacitor and a 10uF E.L. capacitor to output for Ripple & Noise measuring @20MHz BW.
3. Line regulation is measured from high line to low line with full load.
4. Load regulation is measured from 10% to 100% full load.
5. T Version Connection : JST B3P-VH / B4P-VH or equivalent

CFM21SXXX-T

All Dimensions In Inches[mm]
 Tolerance: Inches:x.xx= ±0.02,x.xxx= ±0.01
 Millimeters:x.x= ±0.5,x.xx= ±0.25

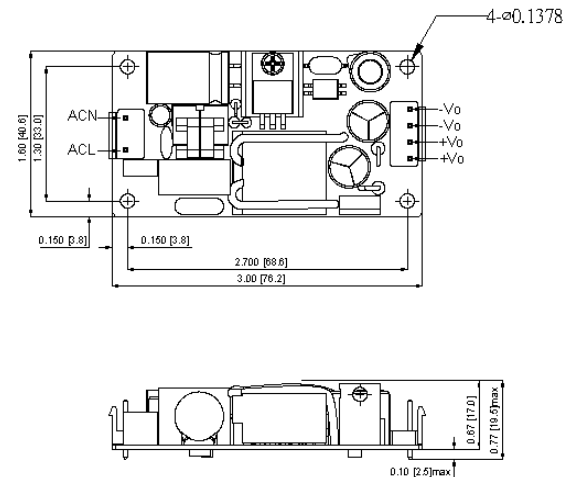

Typical at 25°C, nominal line and 75% load, unless otherwise Specified