



英格爾科技股份有限公司

ENG ELECTRIC CO., LTD.

Revision : 02

Approval Sheet

CUSTOMER: WW73





CUSTOMER MODEL NO.: _____

ENG MODEL NO.: 3A-10CWX12

ENG PART NO.: 3A-10CWX12-021

DESCRIPTION: Switching Power Supply

DATE: 2012-8-1

PREPARED	DESIGNED	CHECKED	APPROVED
		 	

APPROVAL DATE:

CUSTOMER APPROVAL		

總部：台灣桃園縣龜山鄉民生北路1段536號5樓

Head Office: 5F,NO.536, Sec.1, Min Sheng N. Rd.,Kweishan Hsiang,Taoyuan Hsien,Taiwan

TEL: 886-3-2121133 / FAX: 886-3-2121561

工廠：深圳市寶安區福永街道白石廈東區淇譽路180號
中核集團工業區B棟

Factory: Block B, Nuclear Group Industrial District,
No.180,Qiyu Road,Baishixia,Fuyong Street,Bao'an,
Shenzhen,CHINA

TEL: 86-755-27307512

FAX: 86-755-27308049

工廠：深圳市寶安區福永街道新和社區福園一路天瑞工業園
A6棟第五層A

Factory: Area A,5th Floor,Block A6,Tianrui Industrial Zone,
Fuyuan 1st Road,Xinhe Community,Fuyong Street,Bao'an,
Shenzhen,CHINA

TEL: +86-755-27299155

FAX: +86-755-81443663

ENG ELECTRIC CO., LTD.

FILE NO.: EN-RDS-Y303

FILE: 3A-10CWX12-021

SHEET: 01

1 Product Characteristics:

1.1 General Description

Model 3A-10CWX12 is a universal switching-mode power supply, operating at input voltage 90VAC to 264VAC and output voltage of 12VDC with 1A DC load

1.2 Electric Characteristics

1.2.1 Input

No	ITEM	SPECIFICATION
1.	Rated input Voltage	AC100V-240V
	Vibration input Voltage Range	AC90V-264V
2.	Frequency Rated	50-60Hz
	Frequency Vibration	47-63Hz
3.	Input Rated Current	300mA RMS Max
	Inrush Current	25A Max .at 115vac cool start
		50A Max .at 230vac cool start
4.	Leakage current	0.25mA
5.	Average Efficiency	77.76% Min CEC Compliant
6.	Standby Power(No Load)	0.3W Max CEC Compliant

ENG ELECTRIC CO., LTD.

FILE NO.: EN-RDS-Y303

FILE: 3A-10CW12-021

SHEET: 02

1.2.2 Output:

No	ITEM	SPECIFICATION
1.	Output Voltage	12VDC \pm 5%
2.	Output max. Current	1A
3.	Output min. Current	0A
4.	Line regulation	\pm 1%
5.	Load regulation	\pm 5%
6.	Short circuit protection	Output shut down and auto restart
7.	Over voltage protection	The output voltage shall be clamped by internal protection zener
8.	Ripple Voltage (Full load)	150mV (p-p) (100V-240VAC)

1.2.3 HI-POT SPECIFICATION

Input to output : 3000VAC 10mA 1 minute.

1.2.4 Insulation resistance:

Input to output: 500vdc to test the input to output resistance not be less 100M ohm

1.2.5 Safety approved :

Type(Marking)	Country/Region	Standard
PSE	Japan	Safety : 電気用品の技術上の基準を定める省令第1項別表第八1及び2 (102)

1.2.6 PB-free standard: RoHS Compliant

ENG ELECTRIC CO., LTD.

FILE NO.: EN-RDS-Y303

FILE: 3A-10CWX12-021

SHEET:03

1.3 Mechanical Characteristics

1.3.1 AC plug: Direct plug-In UL Type.

1.3.2 DC cord:

(1) Bending test: Life 1000 times 100% guarantee. Swings 120 from

Left to right loading weight 200g , 40 cycle/minute.

(2) Pull test : DC cord and plug ,weight 6kg for 1 minute.

1.3.3 Cord length and output plug: See Reference Att.4

1.3.4 Weight : 85 g

1.3.5 Case Size: (L)60 X (W) 44 X (H) 25mm

1.3.6 Normal operating temperature and humidity

1.3.7 Temperature

Operating: 0°C to 40°C

Storage : -10°C to 70°C

1.3.8 Humidity

Operating : 20% to 80%.

Storage: 10% to 90%

ENG ELECTRIC CO., LTD.

FILE NO.: EN-RDS-Y303

FILE: 3A-10CWX12-021

SHEET:04

2.Attachment:

- (Att.1) Label
- (Att.2) Outdrawing
- (Att.3) Package
- (Att.3.1) Package flow chart
- (Att.4) DC cord drawing

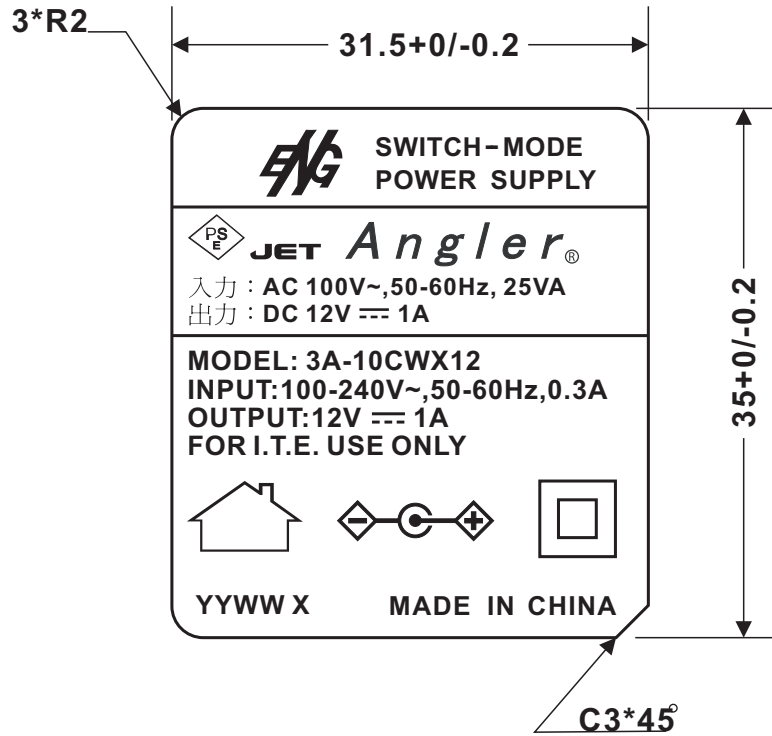

UNIT: mm

YYWW X YY:YEAR WW:WEEK X=S or A(S:FU YONG A:DONG GUAN)

ALUMINUM NAMEPLATE:○ BLACK WORD ON SILVER BASE(銀底黑字)
(鋁板)

○ SILVER WORD ON BLACK BASE(黑底銀字)

METALIZED POLYESTER:○ BLACK WORD ON SILVER BASE(銀底黑字)
(SILVER MATTE)

● SILVER WORD ON BLACK BASE(黑底銀字)

3A-10CW12-021

TOLERANCE				

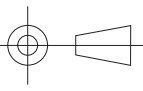
DESIGNED	CHECKED	APPROVED		TITLE	DATE
Wangs	Linli	LNB		LABEL	12/07/31
			UNITS	DRAWING No.	
			mm	N20-WW7300-A31	
			SCALE	DRAWING NAME	REVISION
			2:1	1002	02
ENG ELECTRIC CO., LTD.					

Att.2

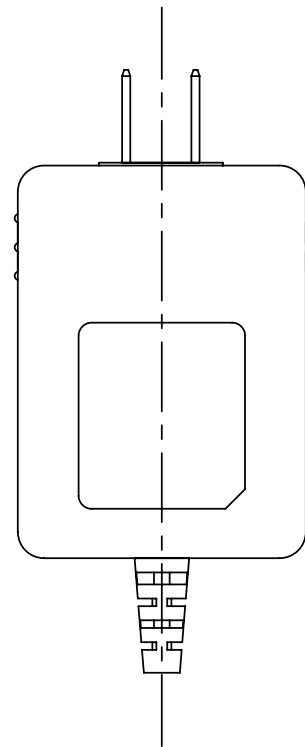
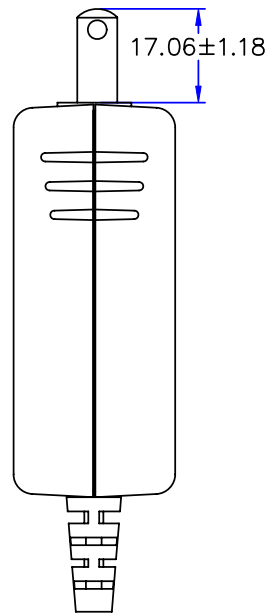
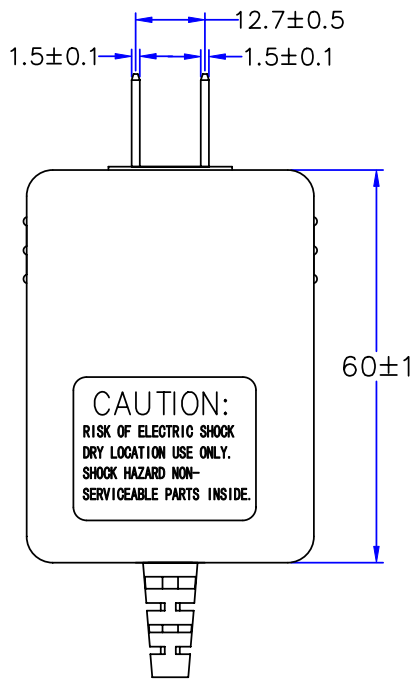
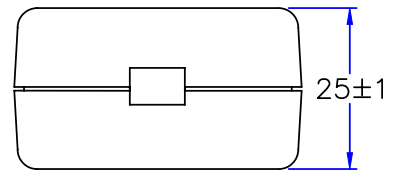
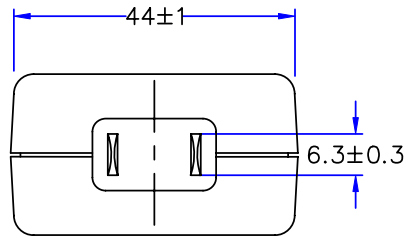

TOLERANCE				

DESIGNED	CHECKED	APPROVED			TITLE	DATE
Hump	zhoujg	zhurg			UNITS	mm
					DRAWING No.	REVISION
					100201-001	01
ENG ELECTRIC CO., LTD					DRAWING NAME	
					100201	

Att.3

CARTON MATERIAL:A=B(6mm)
 CARTON SIZE:388X380X245mm
 外箱尺寸 388X380X245mm
 Q'TY: 80PCS(20*4)
 數量 80PCS(20*4)

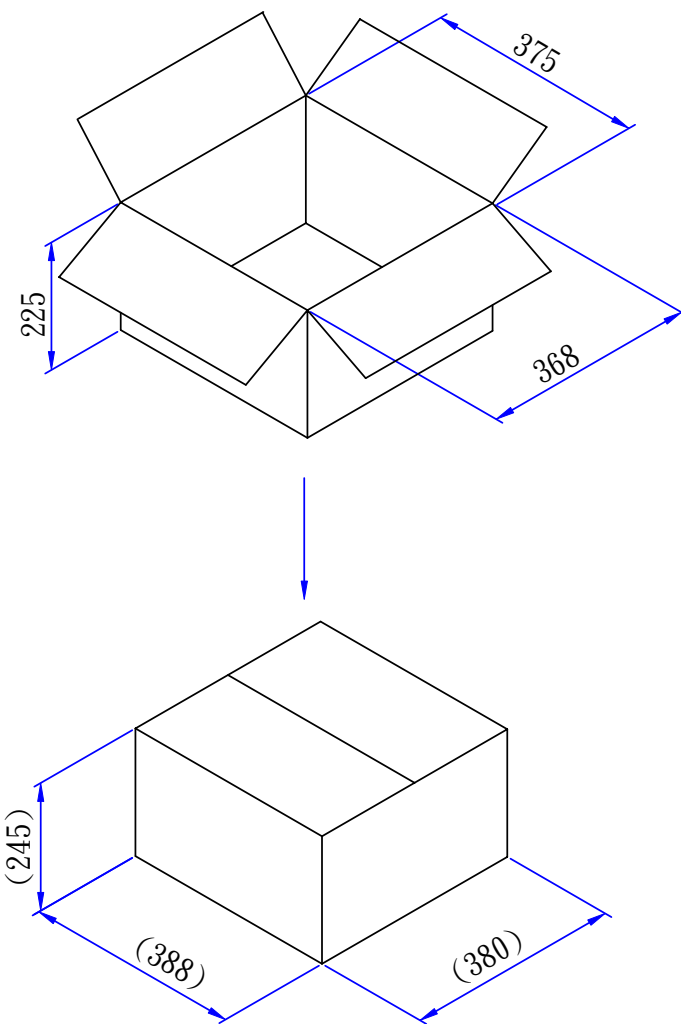

The tolerance of the internal dimensions of the carton is +7/-0

紙箱內度尺寸公差為+7/-0

TOLERANCE				

DESIGNED	CHECKED	APPROVED		TITLE	DATE
LQiang	Linli	LNB		PACKAGE	12/07/31
			UNITS	DRAWING No.	REVISION
			mm	P36-2040-H-50	
			SCALE	DRAWING NAME	02
ENG ELECTRIC CO., LTD.				36-2040-H-50	

Att.3.1

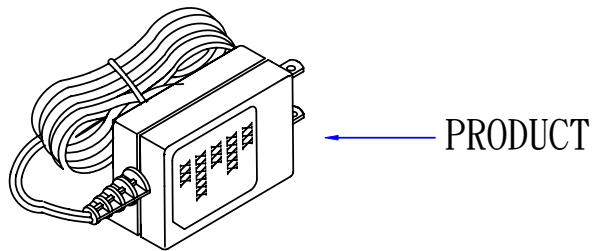

上蓋正中間印字:

10CW12-021

10±1

50±1

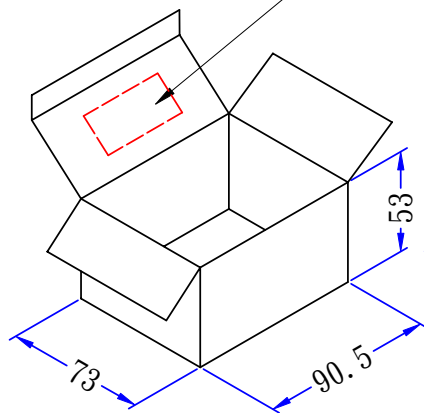

WHITE BOX:36#

The tolerance of the external dimensions of the white box is ± 1
小禮盒外度尺寸公差為 ± 1

TOLERANCE				

DESIGNED	CHECKED	APPROVED		TITLE	DATE
Tanll	Linli	LNB		PACKAGE FLOW CHART	12/08/01
			UNITS	DRAWING No.	
			mm	3A-10CW12-021	
			SCALE	DRAWING NAME	REVISION
ENG ELECTRIC CO., LTD.				36#	02

Att.4

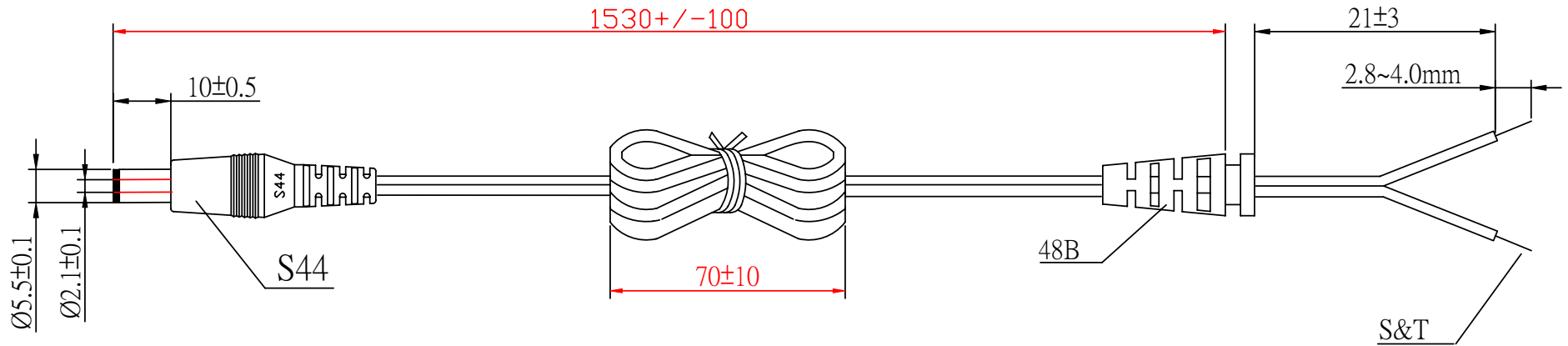

#22AWG X2C UL2468 HAVE ON WORD WIRE IN OUTER, NO WORD WIRE IN INNER(有字接外,無字接內)

Wire OD: Ø1.7X3.4

TOLERANCE				

Parameter request	
搖擺測試 BENDING TEST	a. ±60° b. 吊重200g WEIGHT 200g c. 40回/分 40 ROUNDS/MINUTE d. 1000次/最少 OVER 1000 COUNTS MIN

DESIGNED	CHECKED	APPROVED	TITLE		DATE
Tanll	Linli	LNB	DC CORD		12/08/01
ENG ELECTRIC CO., LTD.			UNITS	mm	DRAWING No. 3A-10CW12-021
			SCALE		
			DRAWING NAME		REVISION
			41-48BS44-03B-00		02